

Welcome Home to Floaticasa

Chat with us at Whatsapp +61 480821729 | Email support@floaticasa.com

We will be online from 9:00 AM - 6:00 PM (UTC+8)



G21-Installation Instructions

(Please refer to the installation video on the product link, or the installation video on YouTube)

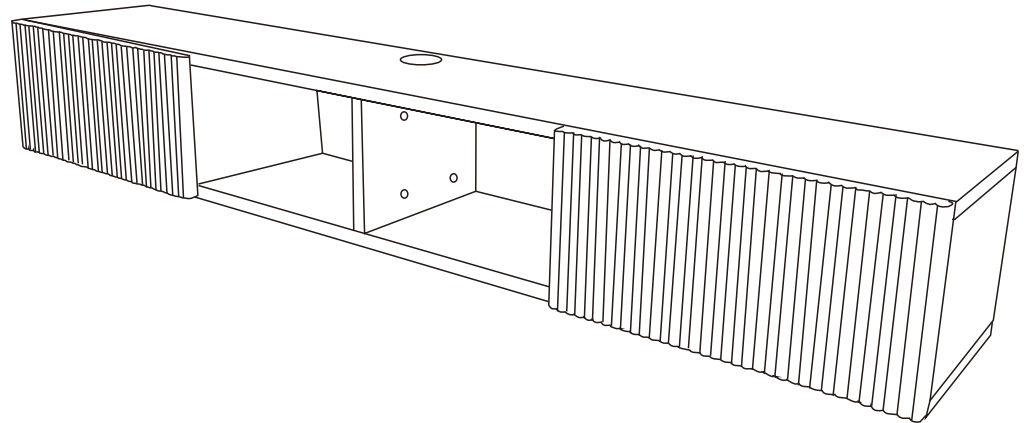

Scan QR code for Luna installation video guide.

Included 8mm screws and anchors
for solid brick walls.
load-bearing walls.
and firedhollow brick walls



If you have drywall, please use the
18mm drill bit(not included) and the
toggle bolts for mounting (package included).
Follow the steps below for mounting on the drywall

- Step 1: Drill 18mm hole on the drywall
- Step 2: Getting through the pre-holes of the tv stand with G & H
- Step 3: Put the Wing Nut on the Toggle Bolt (G) and then pass it through the hole of the drywall
- Step 4: Put all the toggle bolts and butts into the drywall
- Step 5: Screw up all the toggle bolts

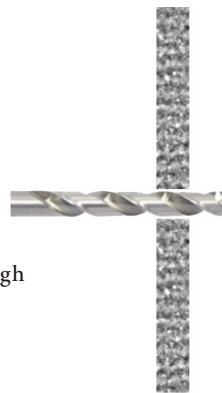

step1



step2

Recommended Number of People for Assembly 2.

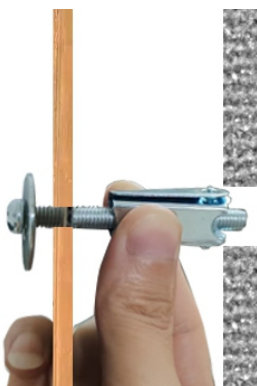

step3

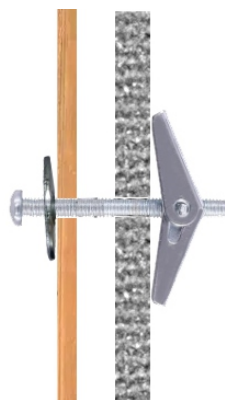

step4



step5

Tools Included

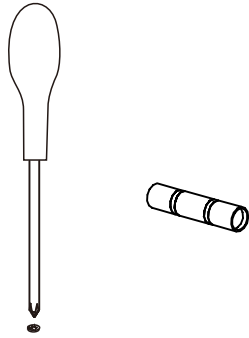

Tools Required



How to adjust the door hinge/hinge.

This screw of the door hinge can adjust the left and right clearance of the door

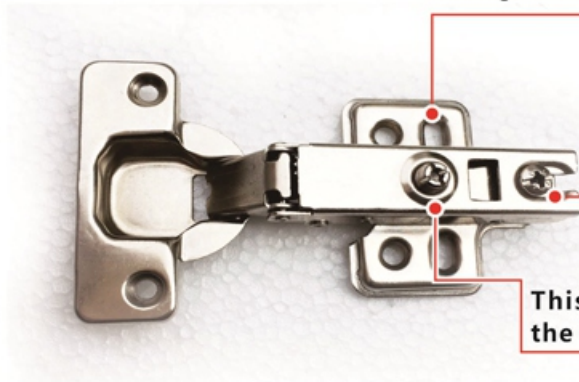

The screw on the door hinge can adjust the gap between the front and rear of the door panel and the side panel.

This screw on the door hinge can adjust the upper and lower clearance of the door panel.

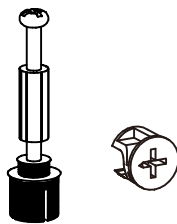

3-in-1 fastener screws

Unscrew it to the left and screw it to the right

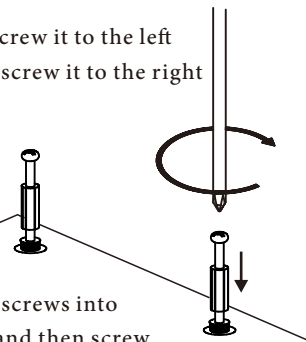

put the 3-in-1 screws into the pre-holes and then screw them with screwdriver or power screwdriver

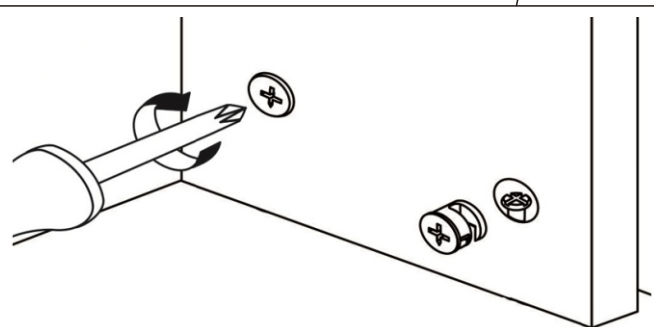
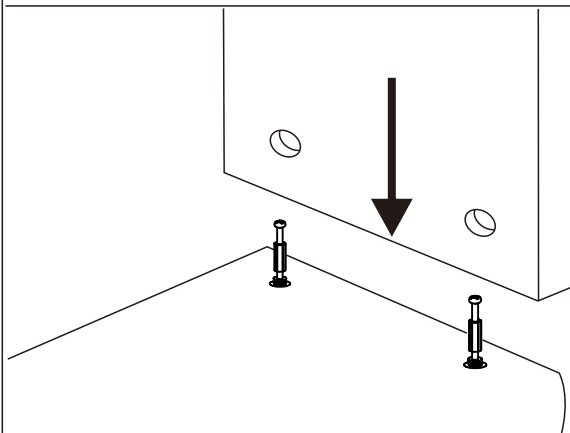

put the fasteners into the holes and screw it with a screwdriver

If the door is uneven once assembled, you can adjust the hinges like following

Adjust left

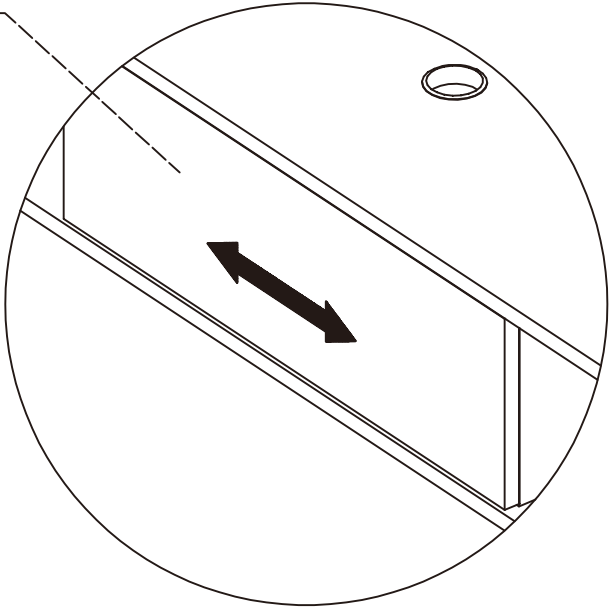
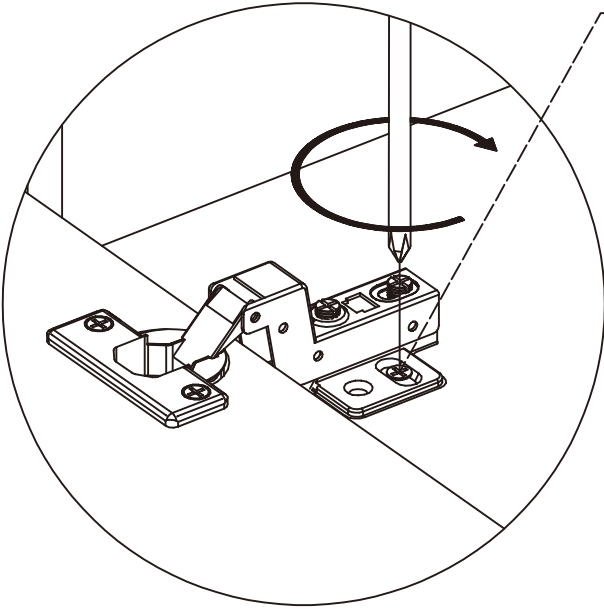

Adjust Height

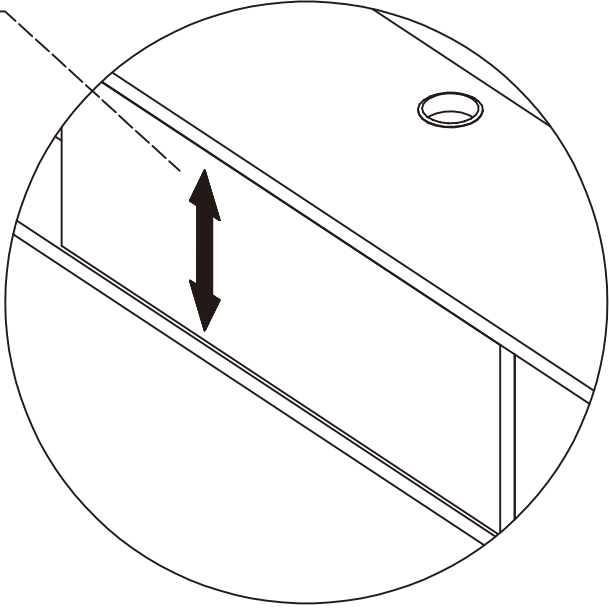
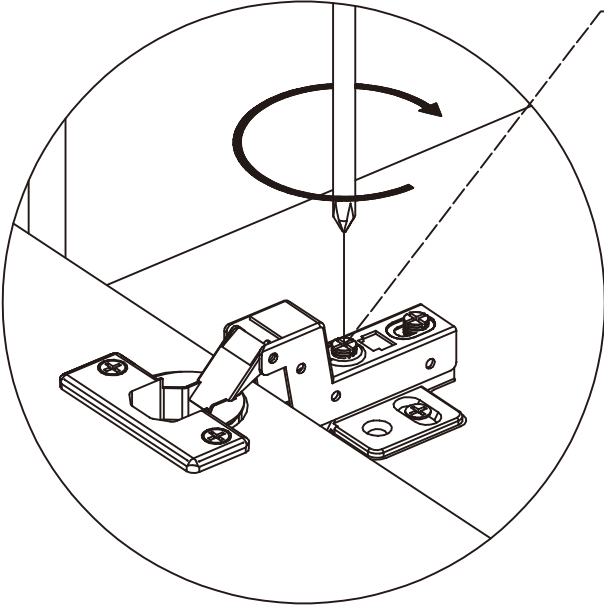

Adjust front

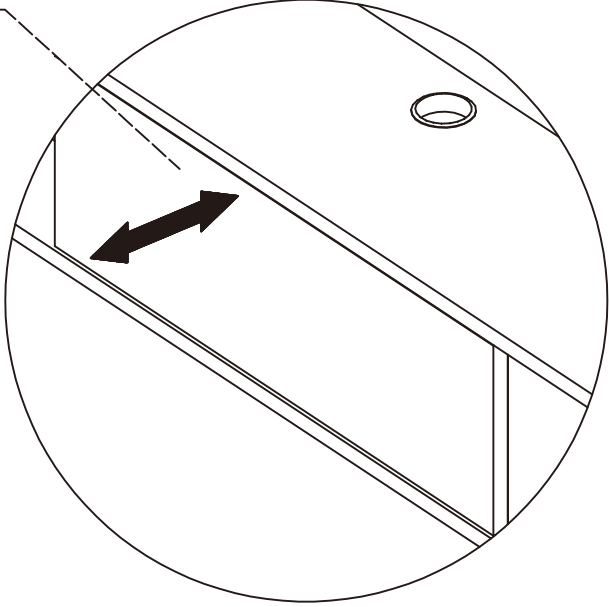
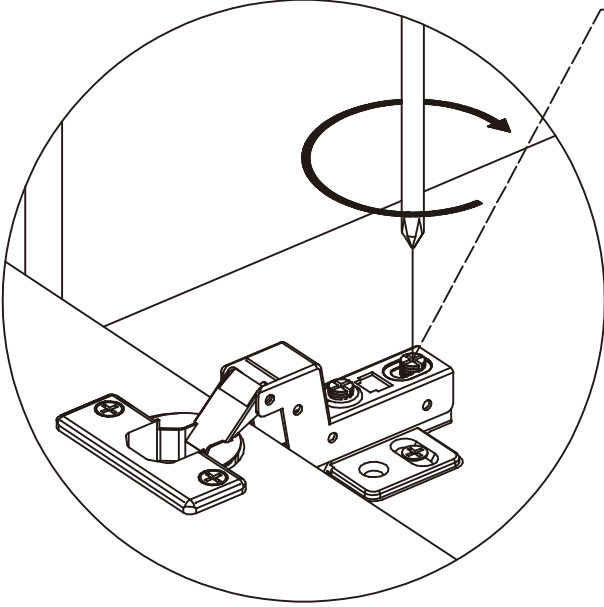

package Included

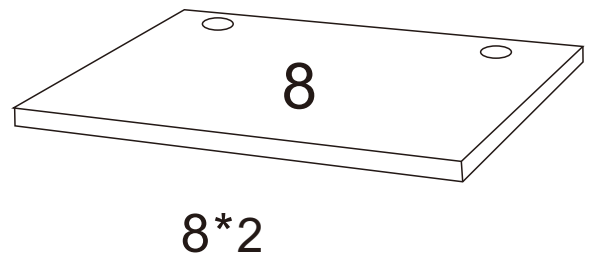
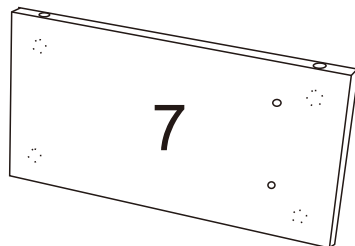
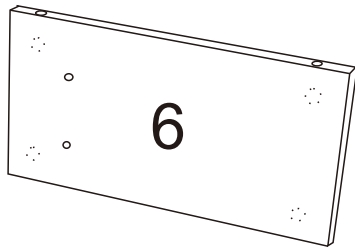
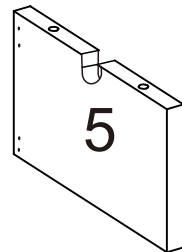
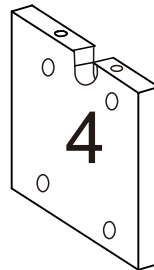
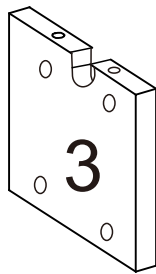
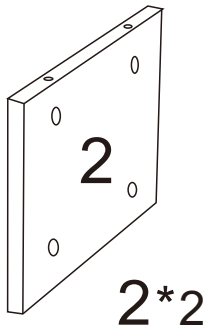
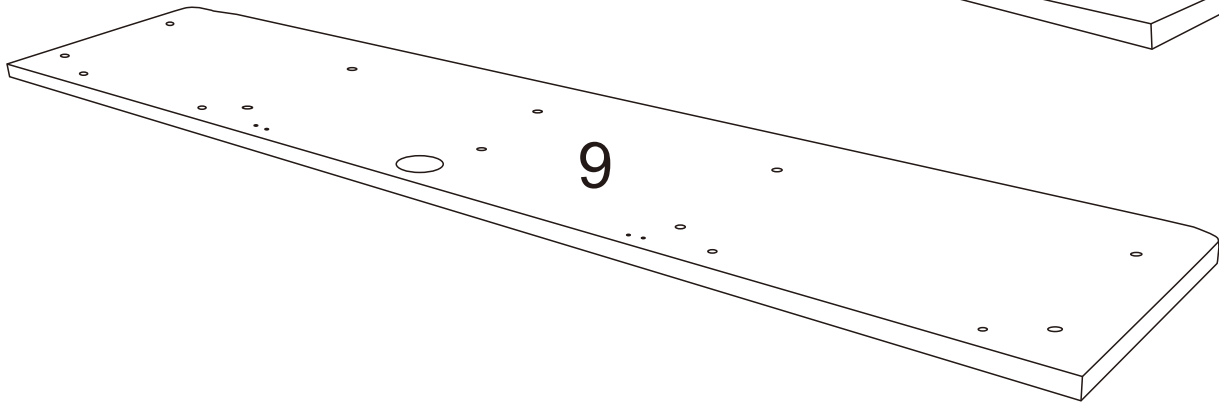
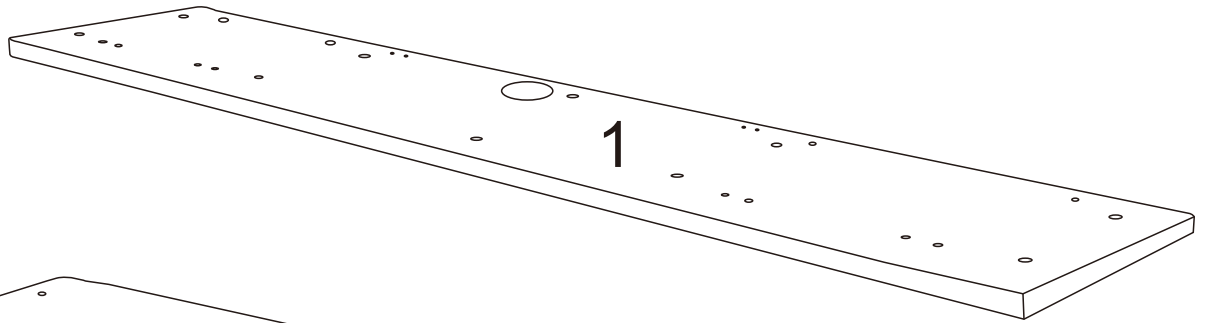

package Included

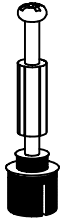

A*28



B*28



C*24

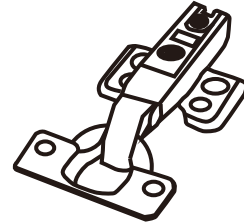

D*4



E*8

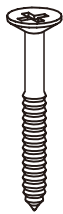

F*8

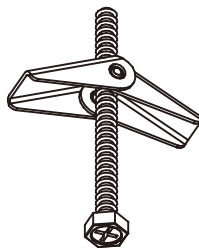

G*8



H*8



stickers

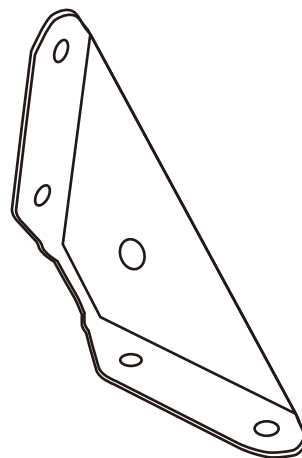

L*4

Make sure Screw up all the screws

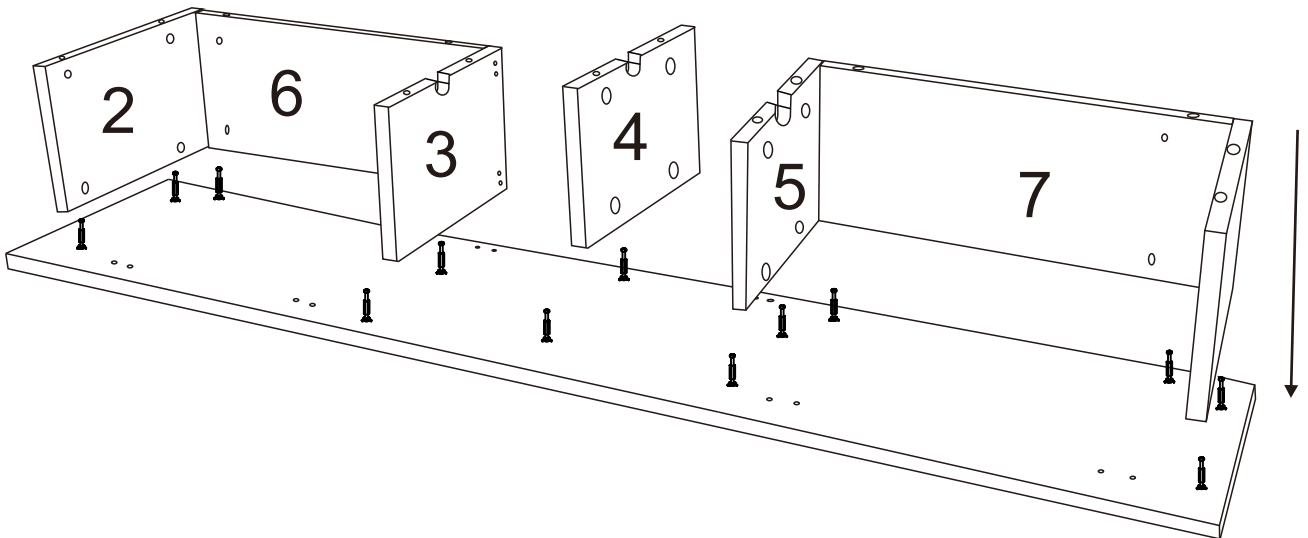
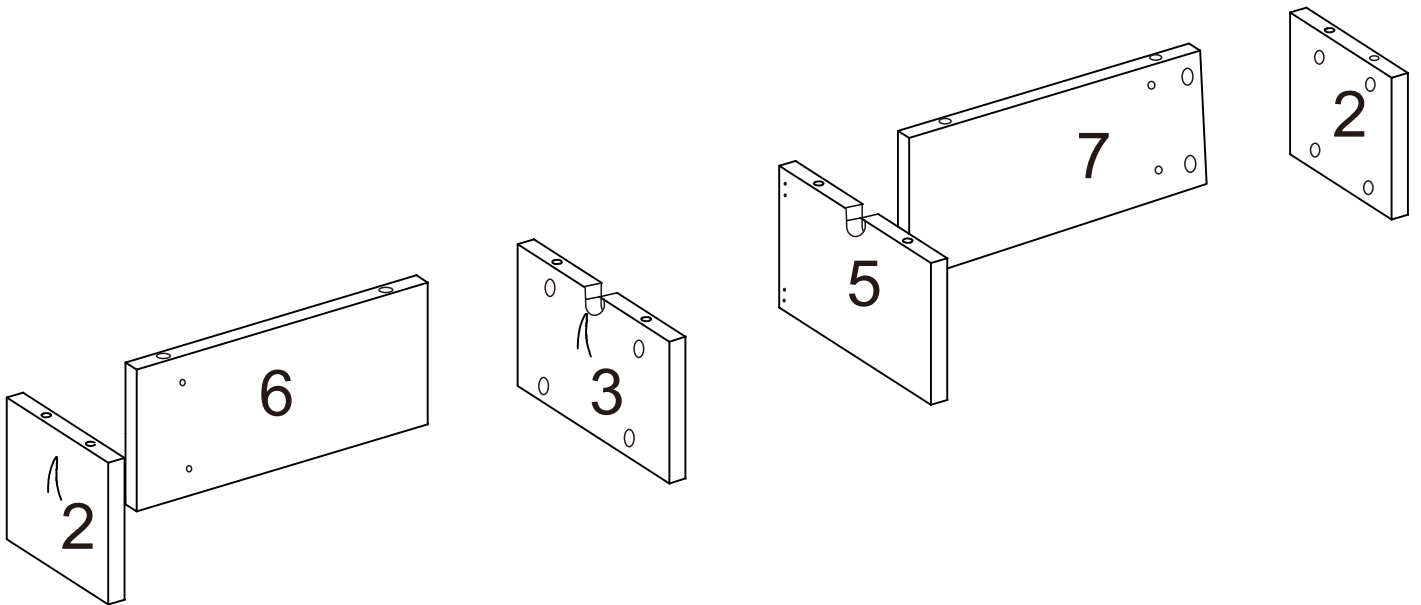
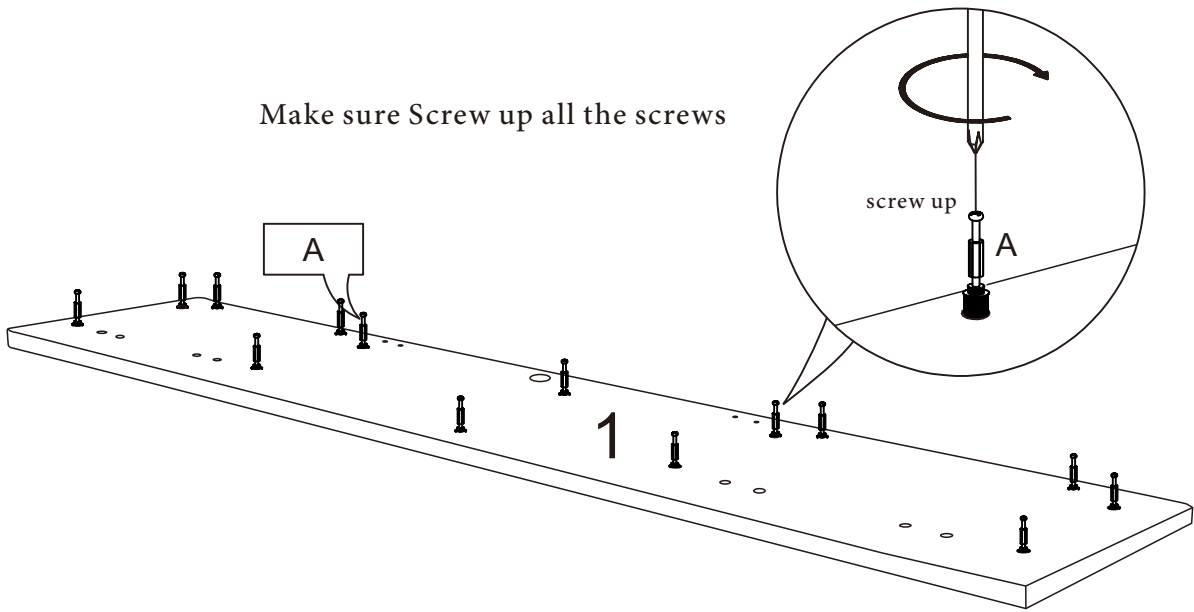

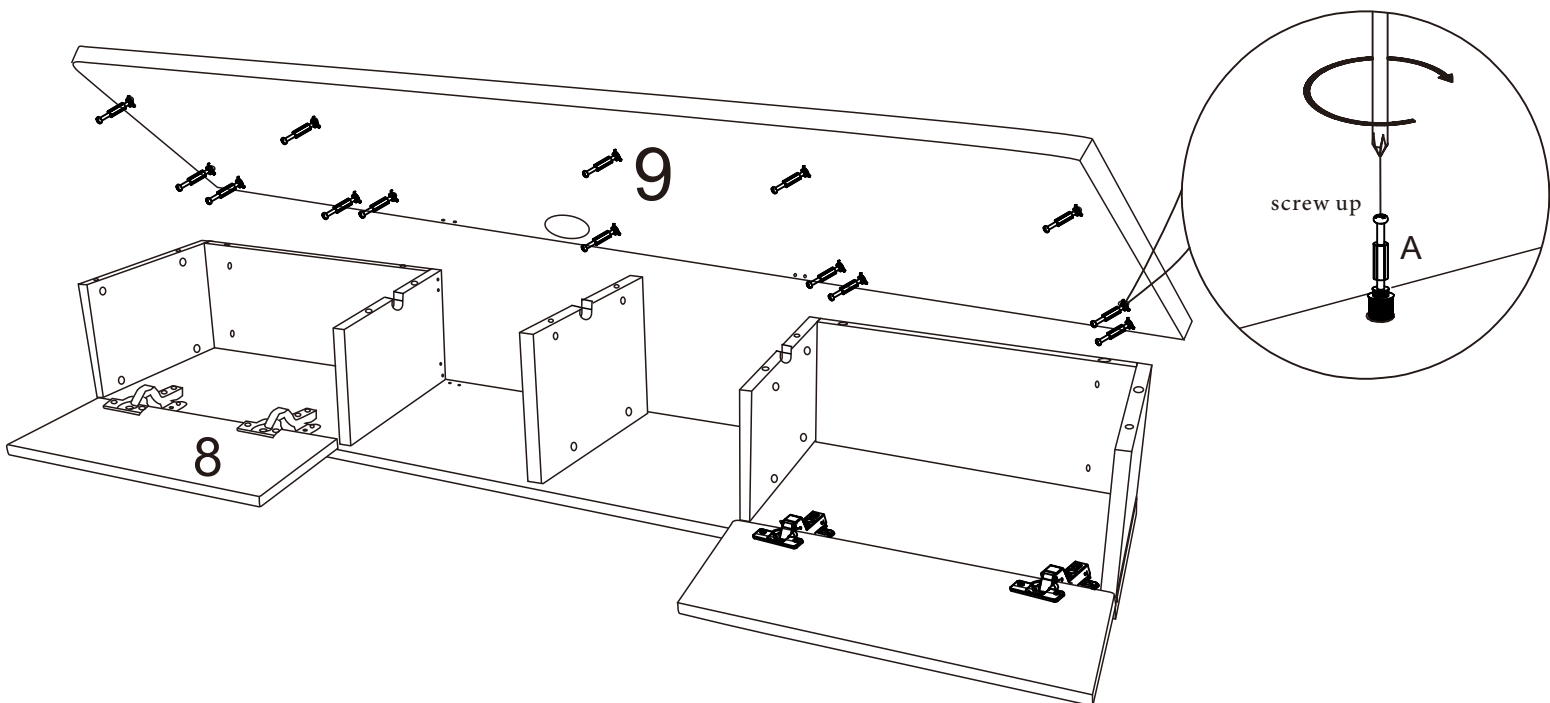
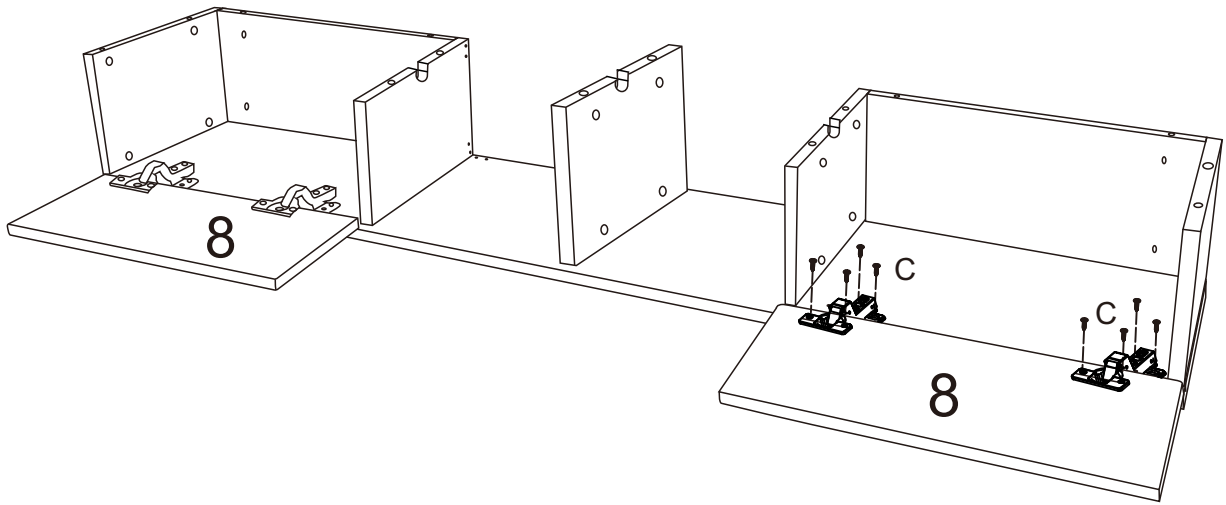
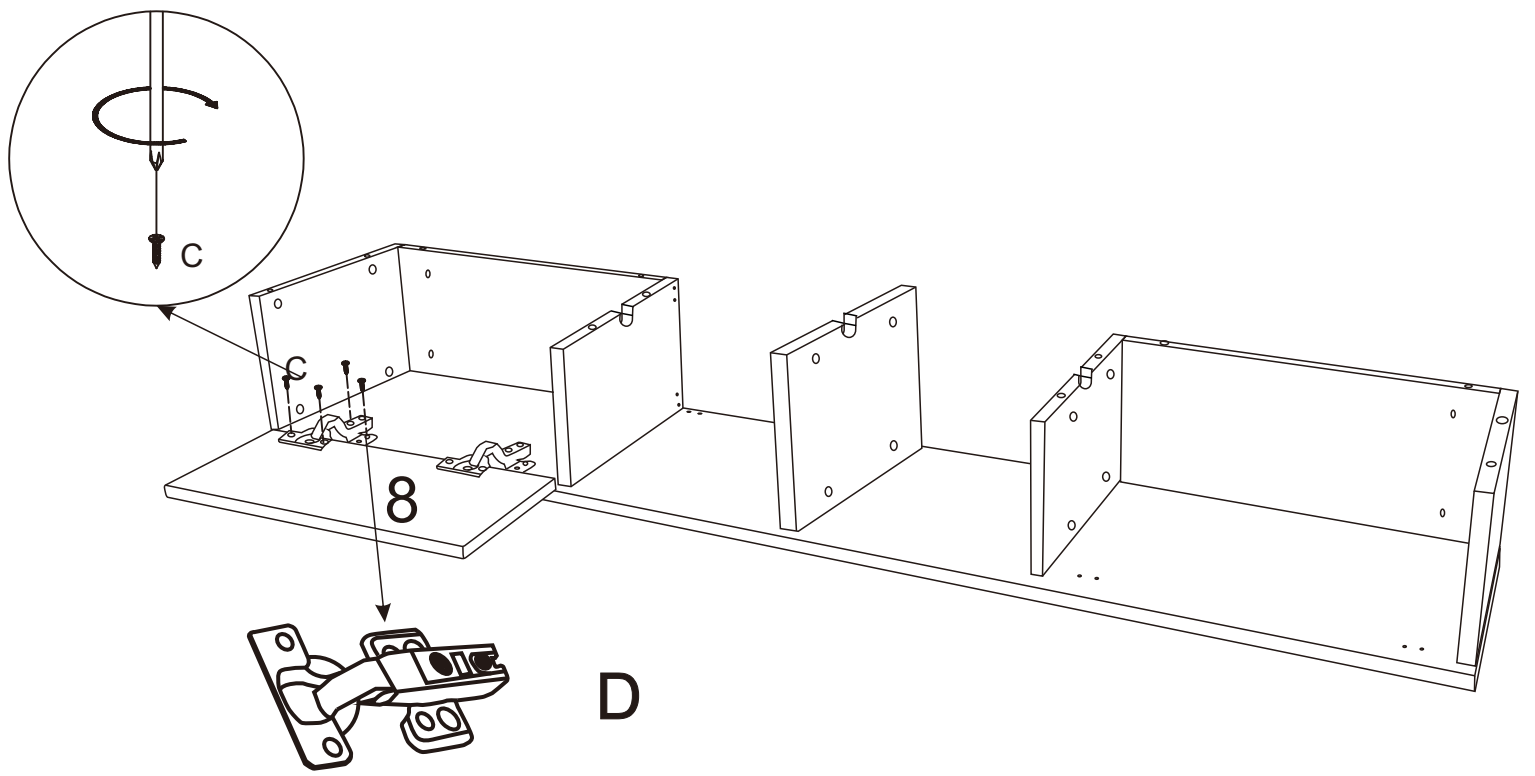

At last, check all the fasteners once more and tighten them.

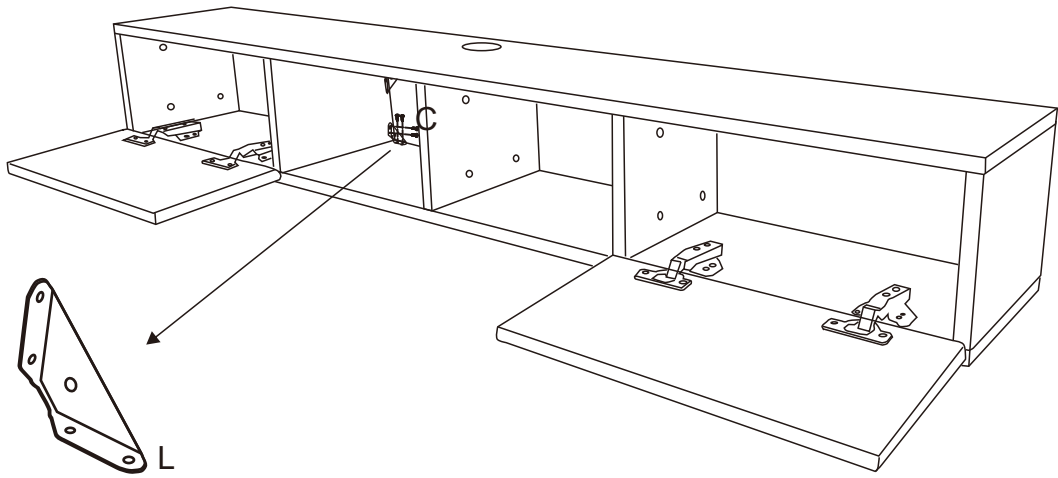
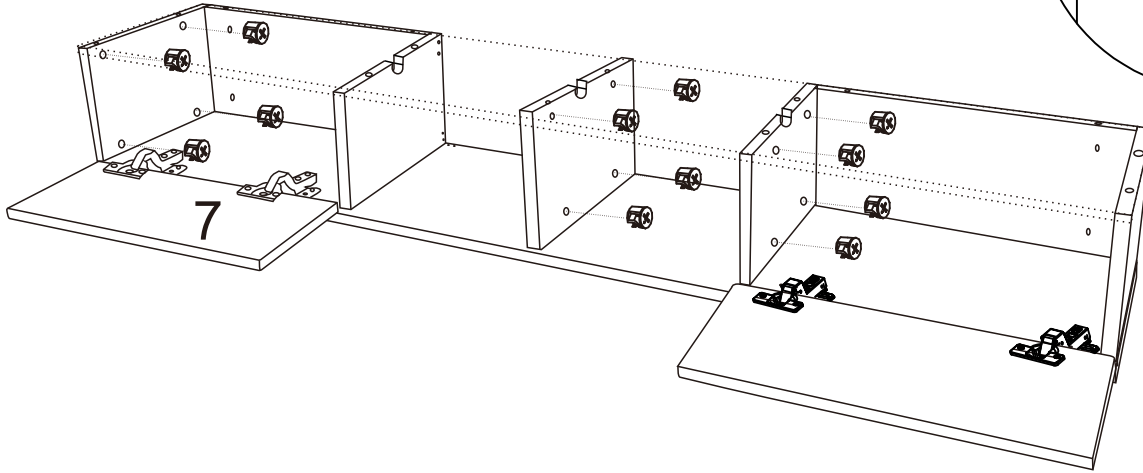
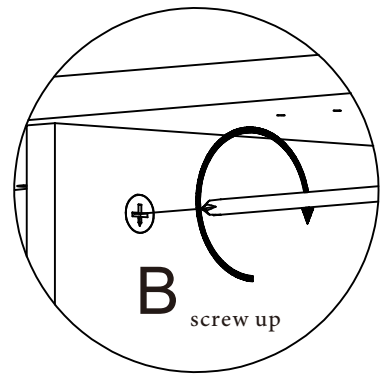

Locate the hole on the wall of the furniture according to the position of the spirit level

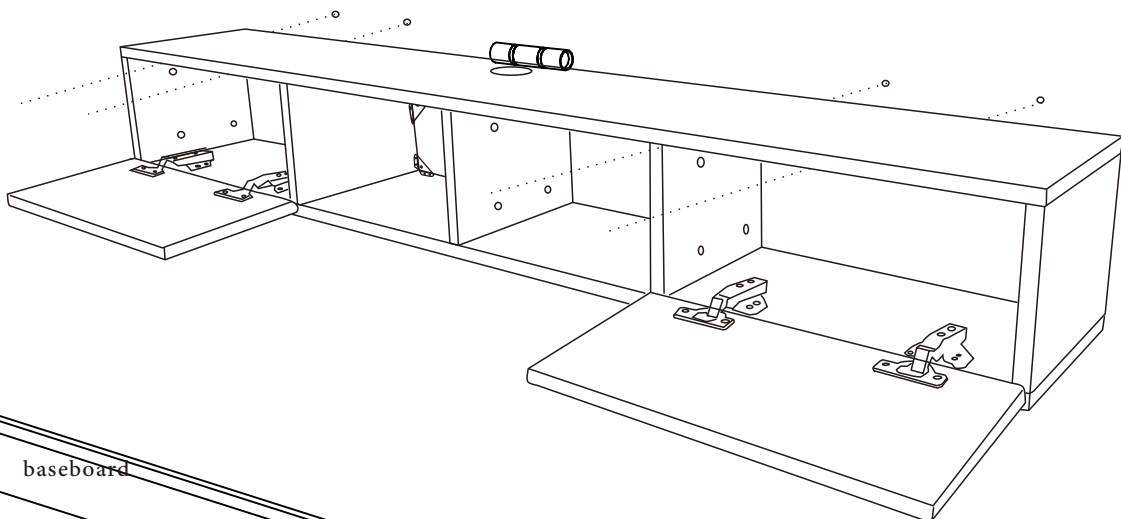

Drill 8mm holes on the wall according to the pre-holes

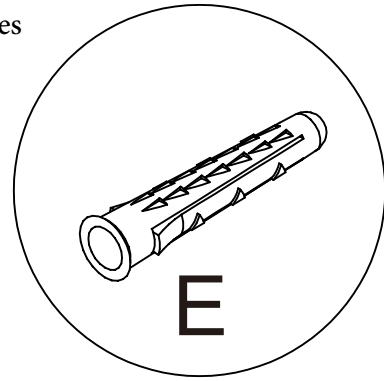
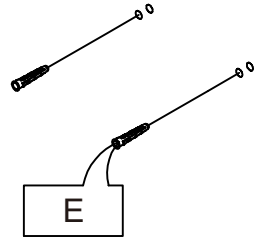

baseboard

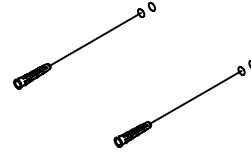

If you have drywall, please use replacement parts G and H to mount it on the wall
(check the steps on page 1)

Tools Recommended For Assembly : Power screwdriver

Once assemble done, put stickers to disguise the exposed screws

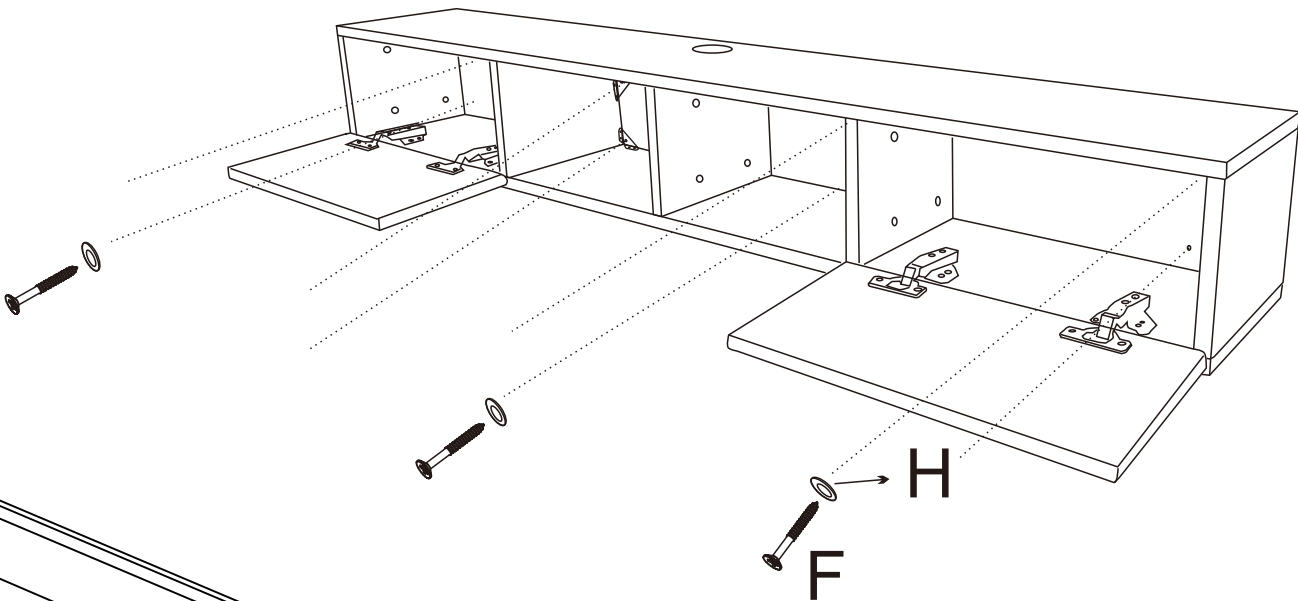

baseboard

Product Instruction

1. Color Variations: Due to differences in screen settings, lighting conditions, and natural wood grain variations, the actual color of your TV stand may vary slightly from what you see online. Each piece is unique, and subtle differences are part of the natural charm of our handcrafted furniture.
2. Measurement Tolerance: All custom and handmade items may have a slight variance in final dimensions. Please allow for a measurement tolerance of ± 0.5 inches (± 1.2 cm), especially for custom-sized pieces. We ensure all measurements are within a reasonable and professional standard.

Product Care

1. For the painted surface, be sure to avoid direct contact with high temperatures. Strong sunlight exposure may cause the product to change color or deform.
2. Use a soft cloth to gently remove dust from the surface of the TV stand. Avoid using abrasive cleaners.

Thank you for choosing Floaticasa

Scan the QR code to get more products.



Frequently Asked Questions

1. What should I do if my product arrives incomplete?

Our products usually pack the loose sheets of material or the assembled cabinets along with their accessories and tools in the same box to ensure that no parts related to the product installation are lost. Once your order is dispatched via FedEx/UPS, you will receive tracking information for each package via email. Carriers may deliver boxes at different times or on different days. If you need further assistance, please reach out to us at support@floaticasa.com.

2. What if my shipment is damaged or a product is defective?

We take great care in packaging, but we know accidents can happen during transit. If you receive a damaged or defective item, please contact us immediately at support@floaticasa.com. Please provide your order number, a detailed description of the issue, and clear photos (or videos) of the damage and the packaging. We will prioritize a resolution, which may include a replacement or a refund.

3. Can I order replacement parts if something is missing or broken during assembly?

Yes! If you find a specific screw, panel, or hardware component is missing or was damaged during the assembly process, we are here to help. You can send your inquiry on Amazon or Email support@floaticasa.com with your Order ID and the Part Letter/Number as indicated in the assembly manual. We will ship the necessary parts to you as quickly as possible.

4. I am having trouble with assembly. Who can help?

Our products are designed for straightforward DIY assembly. However, if you find a step confusing, you can firstly check the Installation Manual to ensuring you are following the steps in the exact order shown. Or you can watch the installation video on our Youtube channel.

5. What is the warranty period for Floaticasa products?

We provide a complimentary one-year warranty on all furniture purchases, covering any accidental damage as well as manufacturer defects in the material and manufacturing. We recommend keeping a copy of your Amazon order details or your website order details as proof of purchase for any future claims.

6. What is your return policy if I change my mind?

We want you to love your home. If you are not satisfied, we offer a 30-day return policy from the date of receipt.

Condition: Items must be returned in their original packaging and in unassembled, "like-new" condition.

How to Start: Please contact us at support@floaticasa.com or message us through Amazon to initiate a return authorization.

Please note that return shipping fees may apply depending on the reason for the return. For full details, please visit our [Shipping & Return Policy] page.

Warranty

We provide a complimentary **one-year warranty** on all furniture purchases, covering any accidental damage as well as manufacturer defects in the material and manufacturing.

Free Manufacturer Warranty Repair or Replacement

Floaticasa offers free repair or replacement for products or parts that are defective under normal usage because of improper material or workmanship during the warranty period.

Free Accidental Damage Repair or Replacement

Products or their parts that are defective due to damage sustained during transit and delivery are eligible for free repair or replacement within the warranty term from Floaticasa.

No Deductible

If something were to happen to your furniture, it would be replaced or repaired for free. No fees. No deductibles. No unstated expenses.

Still have questions? Our customer support team is available online.

Email: support@floaticasa.com Website: www.floaticasa.com

Return & Refund

Your satisfaction is our top priority! If you're not happy with your purchase, we offer a 30-day free return policy. The 30-day period begins on the date your order is marked as delivered by the carrier.

Eligibility Requirements:

- ✔ Items must be in brand-new condition.
- ✔ Uninstalled and/or non-assembled.
- ✔ Unused, with no pieces missing.
- ✔ All original tags and packaging included.

Return Shipping Cost

Floaticasa covers the return shipping cost if your return is due to product damage or production defects.

If the return is not related to a quality issue—for example, a change of mind or slight color variation—you will be responsible for the return shipping cost.

Please note: Minor color differences caused by display settings or lighting are not considered product defects.

Original shipping fees (if any) are non-refundable.

Refunds

Once we receive and inspect your returned item, we will send you a confirmation email within 3-5 business days. After the refund is processed, the amount will be credited to the original payment method.

- ✔ Shipping fees from the original order are non-refundable.
- ✔ Any transfer charges or bank fees incurred are not included in the refund.

Connect With Us!

For any enquiries or issues regarding your purchase, connect with us at www.floaticasa.com

Or chat with us through other channels:

 support@floaticasa.com

 @floaticasa

 @Floaticasa

 @Floaticasa